

# PRODUCT SPECIFICATION

# PS-500

## SPECIFICATIONS

### Product information

Adaptive air volume	700 CFM (1200 m <sup>3</sup> /h)
Application area	60 m <sup>2</sup>
Shell material	ABS Flame retardant material
Weight	450 g
Product size	133*70*154 mm
Noise	≤10 dB

### Electrical

Rated Voltage	12V DC / 24 DC AC 220 /240V
Power	5W

### Ionization Tube

Quantity	1 pcs
Size	80 mm
Estimated Tube Life	17000 Hours
Material	Various composite materials, stainless steel outer mesh



## APPLICATION

PS-500 ionization system is mainly used in the supply and discharge system of medium/large air treatment systems, such as air conditioning ducts, HVAC and other ventilation systems. It can also be installed in the original fresh air system without damaging the original duct structure. It is optional the air pressure switch can be operated simultaneously with the HVAC fan. The plasma intensity can be adjusted by a 3-level knob on the device. The power of the device can be turned off on the device or quickly disconnected on the power cord.

Optional accessories: APP, air pressure switch, ion quantity controller

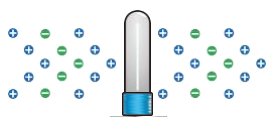
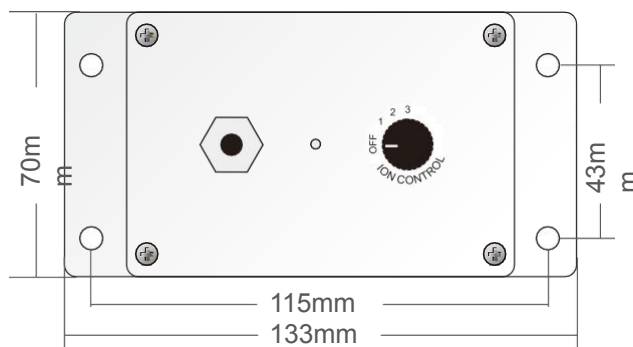
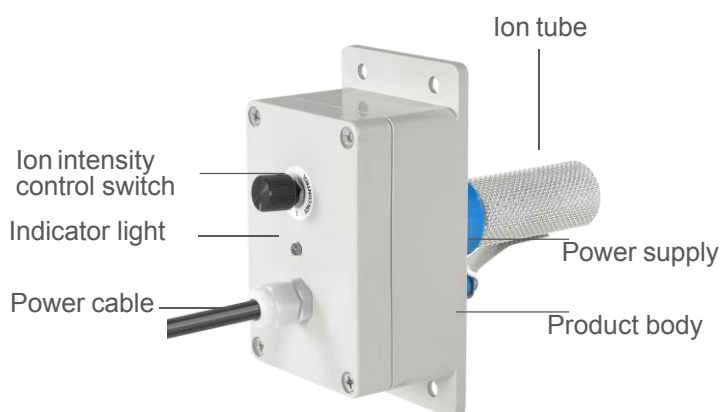

Plasma Ions Sterilization HCoV GX-P2V H1N1 ASFV EV71 HCHO TVOC PM2.5 Odor Air Volume